



User's Manual for Biometric Safe

Read all instructions before using this safe.

WARNING

- New Safe is in Factory Default mode, ANY fingerprint can open the safe. Only successful registered fingerprint can terminate Factory Default mode.
- Register at least two different fingerprints and test a few times before closing the safe door.
- Test with a non-registered fingerprint. If the safe opens, the safe remains in Factory Default mode.
- Avoid leaving safe door open and unattended; it will allow unauthorized individuals to add their fingerprints and/or reprogram the safe, gaining full access to the safe and the contents.
- Test the Emergency Keys and store them in a secure place, NOT inside of the safe.
- To maximize the security and performance of the safe, test registered fingerprints every 6 months.

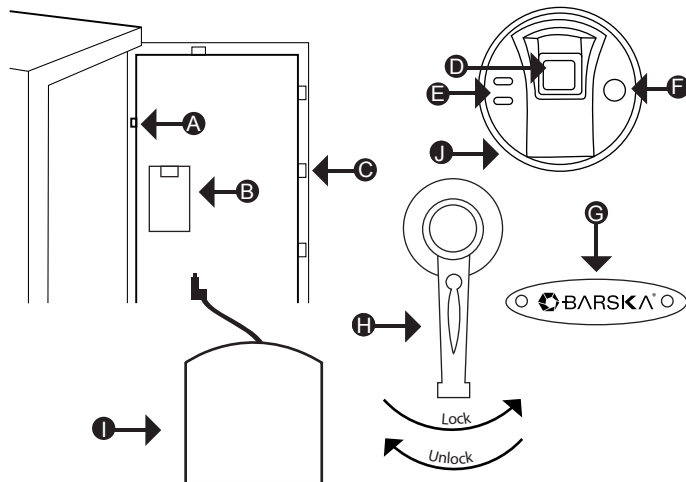

- A. Initialization Button
- B. Battery Compartment
- C. Bolts
- D. Fingerprint Scanner
- E. Indicator Lights
- F. Wake-Up Button

- G. Logo Plate and Emergency Key Access
- H. Handle
- I. External Battery Pack (batteries not included)
- J. External Battery Access

* Actual model may vary

1. INSTALL BATTERIES

1. Remove Battery Compartment (B) cover
2. Insert 4 AA batteries and restore battery cover

2. FINGERPRINT REGISTRATION

IMPORTANT:

The safe is in Factory Default mode, ANY fingerprint can open the safe. Only successful registered fingerprint can terminate Factory Default mode

1. With safe door open, press and release Initialization Button (A)
2. Immediately place a finger on the Fingerprint Scanner (D)
 - Hold finger still
 - 1 beep will be heard recognizing the fingerprint; followed by 2 consecutive beeps
 - Remove finger
 - Registration is complete

Successful Registration

Registration is successful when a total of 3 beeps are heard

Unsuccessful Registration

2 short beeps will be heard; repeat registration process again

3. To register another fingerprint – repeat steps 1 - 2

3. TEST A REGISTERED FINGERPRINT

1. With safe door open, turn Handle (H) counter clockwise to lock the safe
 - Press and release Wake-Up Button (F)
 - Place a non-registered finger on the Fingerprint Scanner (D)
 - Turn Handle (H) clockwise, the door should not open
2. If the Handle (H) turned with a non-registered fingerprint, registration was unsuccessful; and safe remains in Factory Default mode
 - Repeat steps under FINGERPRINT REGISTRATION
3. Press and release Wake-Up Button (F)
 - Place a registered finger on the Fingerprint Scanner (D)
 - Turn Handle (H) clockwise, the door should open

4. CLOSE/OPEN SAFE DOOR

CLOSE: Close door

- Turn Handle (H) counter clockwise to lock the safe

OPEN: Press and release Wake-Up Button (F)

- Place a registered finger on Fingerprint Scanner (D)
- Turn Handle (H) clockwise to open the safe

5. BEEP SOUND OPTIONS

Beep OFF: Press and HOLD the Initialization Button (A) (20 - 30 seconds) until the Indicator Lights (E) flash green once – RELEASE the Initialization Button

Beep ON: Press and HOLD the Initialization Button (A) (20 - 30 seconds) until the Indicator Lights (E) flash green once followed by 1 beep – RELEASE the Initialization Button

6. OPEN SAFE WITH EMERGENCY KEY

1. To expose the Emergency Key access, remove Logo Plate (G) screws with provided Allen wrench
2. Insert Emergency Key into key access, push and turn key counter clockwise, and turn Handle (H) clockwise to open the safe

NOTE: Store Emergency Keys in a secure place, NOT inside of the safe

7. OPEN SAFE WITH EXTERNAL BATTERY PACK

Use this option when internal batteries are low

1. Insert 4 AA batteries
2. Plug into External Battery Access (J)
3. Press and release Wake-Up Button (F)
 - Place a registered finger on Fingerprint Scanner (D)
 - Turn Handle (H) clockwise to open the safe

8. DELETE ALL STORED FINGERPRINTS / RESET TO FACTORY DEFAULT MODE

1. Open safe, remove Battery Compartment (B) cover and all 4 AA batteries
2. Press and release Wake-Up Button (F) a few times until no beeps are heard
3. Press and HOLD the Initialization Button (A)
 - Re-insert batteries, on the 4th battery you will hear 1 beep, followed by 2 consecutive beeps indicating safe is in Factory Default mode
4. RELEASE Initialization Button (A)
5. Repeat steps 1-3 if a total of 3 beeps are not heard
6. Restore Battery Compartment (B) cover
7. All fingerprints stored in the safe have been deleted

NOTE: The safe is in Factory Default mode, ANY fingerprint can open the safe

See reverse side for more information

9. LOW BATTERY WARNING

1. When the door is closed and 3 repetitive beeps are heard, and Indicator Lights (E) flash red, it indicates the batteries are low
2. Replace batteries immediately
 - Open safe, remove Battery Compartment (B) cover and all 4 AA batteries
 - Insert 4 new AA batteries and restore Battery Compartment (B) cover

NOTE: All registered fingerprints remain stored

10. CARE AND MAINTENANCE

- To maximize the security and performance of the safe, keep Fingerprint Scanner (D) clean; use a dry cloth to remove any smudges or prints off the Fingerprint Scanner after each use
- Test registered fingerprints every 6 months
- Keep liquids away from the control panel. Spills on the control panel will cause damage and possibly electric shock
- Secure safe in a proper area to prevent from falling and causing damage or injury
- DO NOT disassemble the product. For all repairs, contact BARSKA Customer Service
- DO NOT use chemicals or cleaning agents to clean the safe

11. MOUNTING INSTRUCTIONS

The safe may be mounted to a wall or floor. Be aware of the load bearing. Failure to do so can result in personal injury and/or damage to property. Use appropriate tools when performing work and always use eye protection

Wall Mounting

Do not mount the safe without anchoring to the wall

- Find the studs in the wall, at your desired location. Most studs are 16 inches or 24 inches apart

- Check the wall for concealed wires or pipes

- Measure the location of the pre-set drill holes; mark their exact position onto the wall ensuring that the studs or anything else behind will not interfere

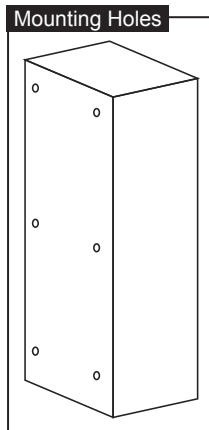

* Actual model may vary

- Drill the appropriate size holes for the anchors you are using
- Carefully press the anchor into the holes at this time
- Mount the safe by running screws from inside of the safe and securing to anchors; ensure the safe is mounted securely

Floor Mounting

- Use proper drill tools depending on the type of floor you are mounting the safe (wood, tile, or concrete)
- Measure the location of the pre-set drill holes; mark their exact position onto the floor
- Drill the appropriate size holes for the anchors you are using
- Carefully press the anchor into the holes at this time
- Mount the safe by running screws from inside of the safe and securing to anchors; ensure the safe is mounted securely



1 YEAR LIMITED WARRANTY

Biometric Safe

BARSKA warrants this new safe to be free of original defects in material and/or workmanship under normal use for a period of twelve (12) months from the date product is received by purchaser. This warranty does not include damage caused by improper installation or maintenance. Damage from misuse, abuse, accident (such as dropping), normal wear and tear, fire, flood, or acts of nature. Damage from service or repairs other than those performed by BARSKA. Labor, cost and shipping charges for the removal and replacement of defective parts beyond the initial twelve-month warranty period. All transportation and shipping charges. Removing or altering the seal under any circumstances will automatically void the warranty.

This warranty is limited to original purchaser and is not transferable. This warranty applies only to products purchased in the United States.

Please email info@barska.com or call 1.888.666.6769 for Return Merchandise Number (RMA#) before any returns. The RMA number must appear on the outside of the shipping package. Product must be packed carefully and sturdily in its original packaging to prevent damage in transit and returned freight pre-paid to:

BARSKA OPTICS
Repair Department
1721 Wright Avenue
La Verne, CA 91750

Please include all of the following when returning BARSKA products for service and/or replacement:

1. Please write your complete details (Name, Address, Telephone #, E-mail address, RMA#, etc.)
2. Purchase receipt or Proof of Purchase. (Original/Copy)
3. A brief explanation of the defect.
4. A Check/Money Order of **\$90.00** to cover inspection, shipping and handling.

*Please allow 6-8 weeks for delivery.

BARSKA will examine and test returned product and repair or replace defective part(s) or units with new part(s) or a new unit if necessary within the warranty period. Purchaser is required to remit **\$90.00** to BARSKA for return shipping and handling at time product is returned. If repair is required after warranty period expiration, purchaser will be charged for replacement parts and return shipping.

BARSKA® Optics shall not be liable for any consequential, incidental and/or contingent damages whatsoever. We will not pay shipping, insurance or transportation charges from you to us, or any import fees, duties and or taxes. This warranty supersedes all previous BARSKA® Optics warranties.