



FingerprintDoorLocks.com

DL300 FINGERPRINT LOCK



USER MANUAL

**Please read this manual carefully before operation.
Please keep this manual for later reference.**

Intelligent Biometric Controls, LLC.

Tel: (513) 336-9292 Fax: (513) 336-0626

[Http://www.fingerprintdoorlocks.com](http://www.fingerprintdoorlocks.com)

E-mail: support@ibcbiometrics.com

All rights reserved. Reproduction without permission is prohibited.

Table of Contents

1. Introduction	01
1.1 Features	01
1.2 Structure & accessories	01
1.3 Checklist	03
1.4 Parameters	03
2. Getting Started	04
2.1 Lock Installation	04
2.2 Fingertip Position for Fingerprint Template Enrollment	04
2.3 Glossary	05
3. Operation	05
3.1 Operation Flowchart for a mechanical key	05
3.2 Unlocking with mechanical key	05
3.3 Locking with mechanical key	05
3.4 Dead Locking	05
3.5 Fingerprint template enrollment	05
3.5.1 Ordinary fingerprint key	06
3.5.2 Master fingerprint key	06
3.6 Unlocking with an enrolled fingerprint	06
3.7 How to set to Normal Open Status	07
3.8 How to cancel Normal Open Status	07
3.9 How to delete enrolled fingerprint	07
4. Maintenance Guide	07
4.1 Daily Maintenance	07
4.2 Caution	08
4.3 Troubleshooting	08
Appendix	09
A. Lock Installation Guide	09
B. Left Handing & Right Handing	13

1. Introduction

1.1 Features



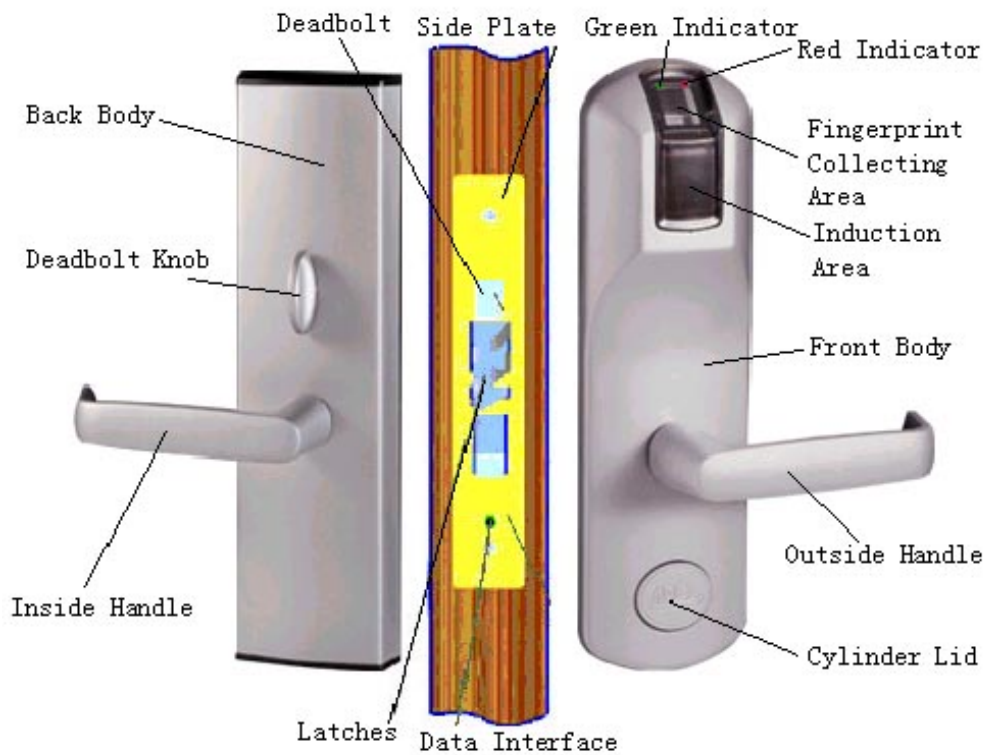

- Adopts optical fingerprint sensor, fingerprints can't be duplicated.
- Fingerprint can be enrolled and erased directly on the lock, no computer needed.
- Two options to unlock the door: fingerprint or mechanical key.
- 180 users maximum
- Normal open status can be set and deleted.
- Two colors options (where "XX" is either "LH" or "RH"):
 - A. DL300-XXB : Polished brass with PVD coated;
 - B. DL300-XXC : Satin chrome
- Standalone version, easy to install.

1.2 Structure & accessories

Lock Structure



Accessories

		
Mechanical keys	3mm Hexagonal Screwdriver	2mm Hexagonal Screwdriver
		
Mechanical Key	Tapping screw	Fixing screw
		
Strike Plate	Strike	

1.3 Checklist

Item	Description	Qty
1	Front body	1pc
2	Back body	1pc
3	Mortise	1pc
4	Handle	2pcs
5	Cylinder	1pc
6	Mechanical key	2pcs
7	Cylinder cover	1pc
8	Hexagonal screwdriver	2pcs
9	Strike	1pc
10	Strike plate	1pc
11	Side plate	1pc
12	Small Fittings	1set
13	Battery	4pcs
14	User guide	1set
15	Quality Certificate	1pc

1.4 Parameters

Operating Environment

Operating Temperature	Between -8°C and +85°C
Storing Temperature	Between -25°C and +85°C
Humidity	Between 20%RH and 90%RH

Technical Parameters

Parameter	Description	Value
Fingerprint sensor	Optical sensor	
Resolution of sensor	500 dpi	
Antistrike ability of sensor surface	Remain good condition after being jabbed with a 4H pencil at a 20cm's distance	
Authentication speed	The motor working time after unlocking with valid fingerprint.	< 1 S
Authentication methods	1:N or 1:1	
FRR	≤ 1%	
FAR	≤ 0.0001%	
Angle for putting finger	+/- 45°	
Fingerprint scanning	Twice to get one fingerprint template	
Fingerprint template saved	All enrolled fingerprint template will be saved while replacing new batteries	
Operating Voltage	4 AA alkaline batteries	4.5 V~6.0 V
Battery Life	The time 4 new batteries run down	12 months
Static current	When the lock is in static status.	<10μA
Dynamic current	The working current during unlocking process	110~180mA
User capacity	The maximum No. of fingerprints could be enrolled into the lock.	180pcs

2. Get started

2.1 Lock Installation

Refer to **Appendix A** for detailed lock installation steps.

- Power supply on and Initialization

Step 1 Put 4 AA alkaline batteries into the battery box;

Step 2 The red and green indicators flash once at the same time;

Step 3 The motor makes a “zi” sound;

Step 4 The buzzer makes a long beep.

Step 5 The lock has been initialized successfully.

2.2 Fingertip Position for Fingerprint Template Enrollment

Put a fingertip on the sensor, this fingerprint lock allows the deviation angle to the side not exceeding $\pm 45^\circ$.



✓correct



X wrong

Thumb, forefinger and middle finger are recommended for fingerprint template enrollment. Note the followings while enrolling.

1. Place the fingertip center right on the sensor.
2. Press flat and evenly the capture window with a fingertip, and cover the sensor surface as wide as possible.
3. Place a fingertip at nearest the same position of the sensor each time after the fingerprint template is collected.
4. Slightly press the sensor if a fingertip is wet and dry it if necessary.
5. Press the sensor with a bit bigger strength if the fingertip is too dry.

Note: Select a fingertip with perfect finger mark to enroll its fingerprint template.

2.3 Glossary

Normal open status: The lock keeps open no matter the door is closed or not. The lock can be opened by rotating outside handle any time without neither mechanical key nor fingerprints.

Locking Status: The door will be locked up when it is closed and a key is needed to open the door.

Dead Locked Status: The dead bolt is extended when the door is locked up.

3. Operation

3.1 Operation Flowchart for a Mechanical Key:

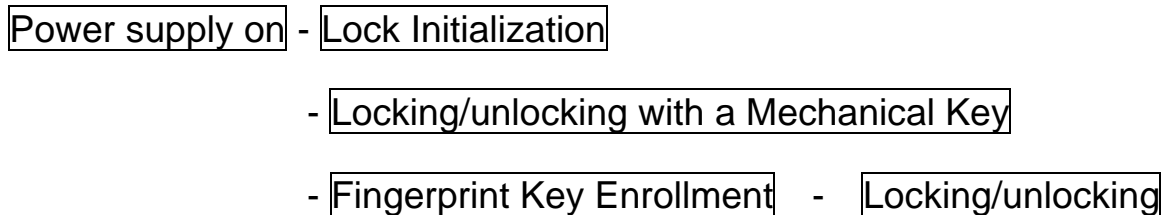

3.2 Unlocking with mechanical key

Step 1: Plug the 2mm hexagonal screwdriver into the small hole at the bottom of the front body of the lock to loosen the screw inside – turn the screwdriver slightly to avoid the screw from dropping, till the cylinder can be taken off.

Step 2: Insert a mechanical key in the cylinder and turn it down 180° clockwise for right handing doors or anticlockwise for left handing doors, the buzzer will make a long beep and the door is unlocked.

3.3 Locking with mechanical key

After the door being unlocked with a mechanical key, turn back the mechanical key up 180° anticlockwise for right handing doors or clockwise for left handing doors and pull it out. Cover the cylinder with the cylinder cover. The Door has been automatically locked up.

3.4 Dead Locking

To dead lock the door inside: turn the dead bolt knob to extend the rectangular dead bolt.

3.5 Fingerprint Template Enrollment

3.5.1 Ordinary fingerprint key : means fingerprints which can only unlock while the deadbolt doesn't extend (The door is locked with latches only, but the deadbolt doesn't extend).

- Step 1. Use the 2mm hexagonal screwdriver to take off the cylinder cover. (After the operation with a mechanical key, cover the cylinder back in the correct direction and press it with strength).
- Step 2. DO NOT extend the deadbolt.
- Step 3. Insert a mechanical key into the cylinder and turn it 180° clockwise, the buzzer makes a long beep and the lock has been unlocked and entered into fingerprint template enrollment status.
- Step 4. Put a fingertip onto the sensor, rotate outside handle with another hand, the red indicator flashes, which is the first enrollment. Move your finger away after a long beep is heard.
- Step 5. Put the same fingertip onto the sensor IMMEDIATELY for second enrollment, move the finger away after 2 long beeps are heard. The 2 long beeps indicate that the fingerprint template enrollment has succeeded.
Note: If 2 short beeps were heard, this indicates the failure of enrollment. Please try again.
- Step 6. Repeat **Step1** to **Step 5** to enroll more fingerprints.
- Step 7. Turn the mechanical key back to original position to finish the fingerprint enrollment status, and the lock is in locking status.

3.5.2 Master fingerprint key : means fingerprints which can even unlock while the deadbolt extends (The door is locked with both latches and deadbolt).

- Step 1. Use the 2mm hexagonal screwdriver to take off the cylinder cover. (After the operation with a mechanical key, cover the cylinder back in the correct direction and press it with strength).
- Step 2. Insert a mechanical key into the cylinder and turn it 180° clockwise, the buzzer makes a long beep and the lock has been unlocked and entered into fingerprint template enrollment status.
- Step 3. Put a fingertip onto the sensor, rotate outside handle with another hand, the red indicator flashes, which starts the first enrollment.
- Step 4. IMMEDIATELY extend the deadbolt with another hand, make sure the deadbolt was extended before you hear a long beep. Move your finger away after a long beep is heard.
- Step 5. Put the same fingertip onto the sensor IMMEDIATELY for second enrollment, move the finger away after 2 long beeps are heard. The 2 long beeps indicate that the fingerprint template enrollment has succeeded.
Note: If 2 short beeps were heard, this indicates the failure of enrollment. Please try again.
- Step 6. Repeat **Step1** to **Step 5** to enroll more fingerprints.
- Step 7. Turn the mechanical key back to original position to finish the fingerprint enrollment status, and the lock is in locking status.

3.6 Unlocking with an enrolled fingerprint

Make sure the door is in locking status before you unlock it.

Step 1. Put an enrolled fingertip onto the sensor and rotate the handle. The green indicator should light up and red indicator should flash.

Step 2. The motor in the lock makes a “zi” sound and the buzzer makes a long beep.

Step 3. Rotate the handle to open the door.

Note:

1. The door will be locked automatically if its handle hasn't been rotated within five seconds after the long beep.
2. If the lock denies a valid fingerprint along with the flashes of the red indicator and two short beeps of “di”, it indicates that fingertip's position is incorrect. Adjust its position and try again.
3. The response of the lock will be the same as in No 2 if an invalid fingerprint is used to unlock the door.

3.7 How to set to Normal Open Status

Note: Normal Open Status can only be set with enrolled fingerprint.

(1) During locking status, put an enrolled fingerprint on the sensor, rotate outdoor handle, the green and red indicators flash, 3 seconds later, the motor drives, move away the finger from the sensor, rotate the handle and the lock will come into unlocking status;

(2) Immediately put the finger onto the sensor, rotate the handle twice, a long beep will be heard. The lock has been set to Normal Open Status.

3.8 How to cancel Normal Open Status

When a lock is in Normal Open Status, rotate the deadbolt knob to extend the deadbolt latch, the motor makes a “zi” sound and the door is locked.

The Normal Open status has been cancelled.

3.9 How to delete enrolled fingerprints?

Step 1. Insert a mechanical key in the cylinder and turn it clockwise to unlock the door,

Step 2. After a long beep is heard, stop power supply by taking out 1 of the batteries.

Step 3 Ten seconds later, replace the battery being took out.

Step 4. The red and green indicators flash once at the same time. The motor makes a “zi” sound and the buzzer makes a long beep.

Step 5. Loose the handle and turn the mechanical key back to the original position to lock the door.

CAUTION: All fingerprint templates stored in the lock will be deleted. Please make sure you want to do so.

4 Maintenance Guide

4.1 Daily Maintenance

Sensor & Lock Surface Clean	Daily Maintenance
Keep sensor & lock surface clean and dry. Clean it with soft and dry cloth if any stain on the lock surface.	Check fixing screws, handles, side plates and strike plates every two months. Fasten any loosen screws.

4.2 Caution

Do not open the door with a wet finger.
Do not touch the surface with corrosive materials.
Do not hang anything on the handle.
Adjust the position of the strike plate immediately if the latches can not extended into it due to the door frame distortion.
The maximum number of enrolled fingerprints is 180 pcs. You need to clear the lock when the memory is full.
When the batteries are running down, the red indicator flashed to alert low voltage. Although you can still unlock the door 20-30 times, you should replace new batteries ASAP.
Keep the mechanical keys carefully to prevent from being burglarized.

4.3 Trouble Shooting

Problem	Possible Reasons	Solutions
When putting a fingertip on the capture window, the red indicator light up and the buzzer makes two short beeps, but the door cannot be opened.	1. Invalid fingerprint "key"; 2. Deleted fingerprint "key".	Use a valid fingerprint Key.
When putting a fingertip with a valid fingerprint "key" on the sensor, the red indicator flashes and the buzzer makes two short beeps, but the door cannot be opened.	The fingertip is wet.	Dry the fingertip with soft and dry cloth and try again
During the collection operation, the green indicator flashes after the finger moves away, and the red indicator makes a flash and then goes out.	Incorrect fingertip position is used.	Adjust the fingertip position and try again.
During the collection operation, a fingerprint template has been collected successfully more than once, and then the red indicator flashes and the buzzer make two short beeps.	The enrollment fails as no common fingerprint template part can form from the several collections.	Repeat the enrollment operation.

Appendix:

A: Lock Installation Guide

1. Door Requirement

- 1.1 Wooden door with thickness from 38mm to 55mm.
- 1.2 If the door surface is decorated, the distance from the decorative edge to the doorframe must be between 108mm and 150mm.
- 1.3 If the lock is to be installed on a hollow door, underlay with a piece of wooden board the part of the door where the lock body is to be fixed on.
- 1.4 Thickness of door frame must be >30mm.
- 1.5 Locate the centerline of handle of the lock according to user's request; the recommended height for it is one meter above the ground.

2. Installation Tools

Auger: Auger bit: ϕ 12mm to ϕ 13mm, ϕ 22mm; Power Drill;
Drill bit: ϕ 35mm to ϕ 40mm; Power saw; Power saw blade
Chisel; Hammer; Screwdriver; Thread board; Template; Pencil

3. Installation Steps:

- Step 1. Draw the centerline of handle according to user's request,
Draw installation lines according to the template (Refer to **Diagram 1**);
- Step 2. With ϕ 22mm auger bit to drill the six holes according to the drawn lines on the door side (Refer to **Diagram 1**). The holes' depth should be 11-12cm. (Refer to **Diagram 2**). With a chisel excavate the six holes to make a rectangle slot, and check and adjust it to fit the size of the mortise (Refer to **Diagram 3**).
- Step 3. With ϕ 12mm-13mm auger bit drill the four holes for fixing screws and one deadbolt knob hole on the exterior and interior faces of the door according to the drawn lines. (Refer to **Diagram 4**)
- Step 4. According to the template, with a power saw cut a square hole, with a ϕ 35mm-40mm drill bit drill a cylinder hole and a handle hole.
- Step 5. Install the mortise and fix it with a tapping screw. Install side plate and fix it with screws. (Refer to **Diagram 5**)
- Step 6 Install the lock cylinder: insert a mechanical key halfway in the cylinder and turn it to screw the cylinder slightly till a position that the cylinder lid keeps even with the lock surface when it has been put on, adjust the cylinder with the mechanical key to make the key slot in horizontal position, and fix it with a screw at the side of the door. (Refer to **Diagram 5**)

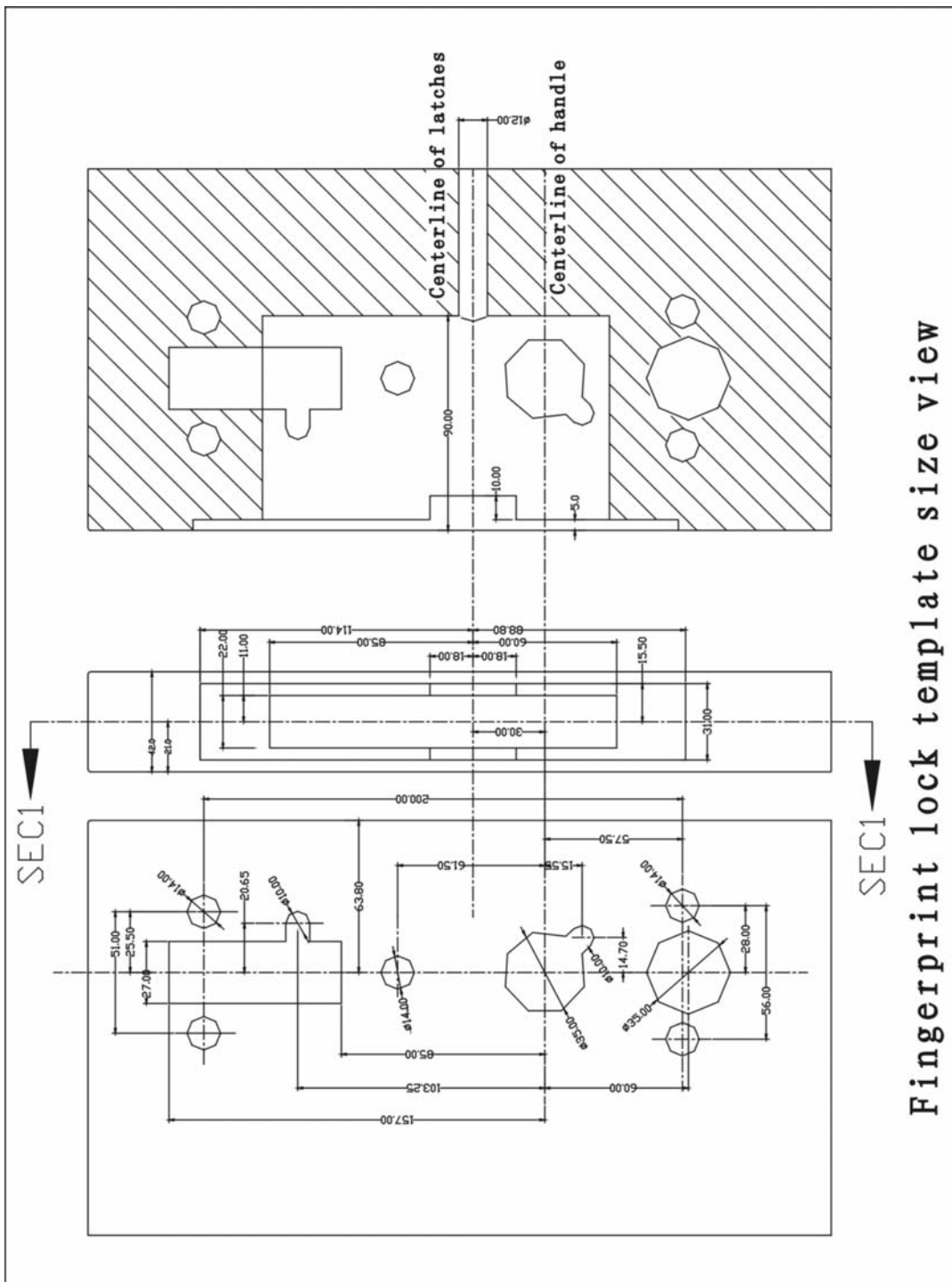

Diagram 1

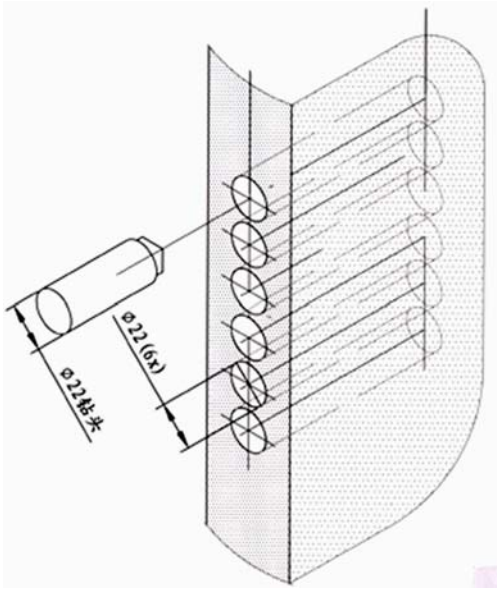

Diagram 2

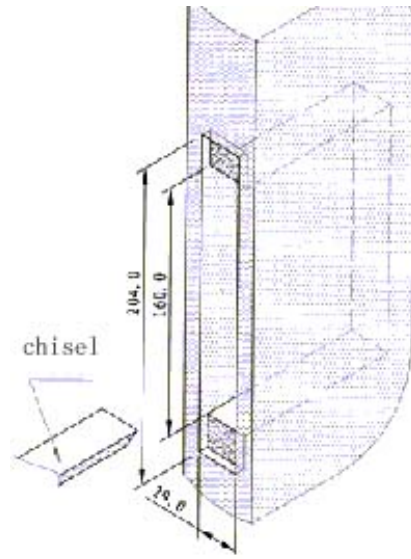

Diagram 3

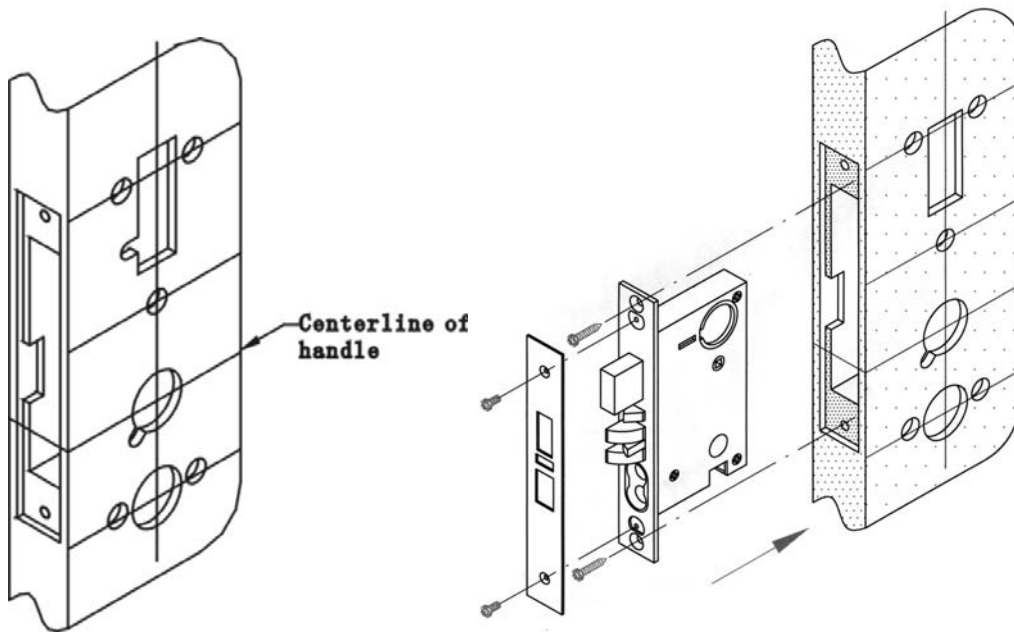

Diagram 4

Diagram 5

Step 7. After the cylinder has been installed, insert the end with gutters on edges of the long square shaft into the square hole on the door to locate the outside handle.

Step 8. Insert the fixing shaft in the hole of the handle slightly to install the front body. Make the wire socket on the front body through the square hole.

Step 9. Install the back body : connect the back body to the mortise by screws , put in 4 AA

alkaline batteries. (Refer to **Diagram 6**).

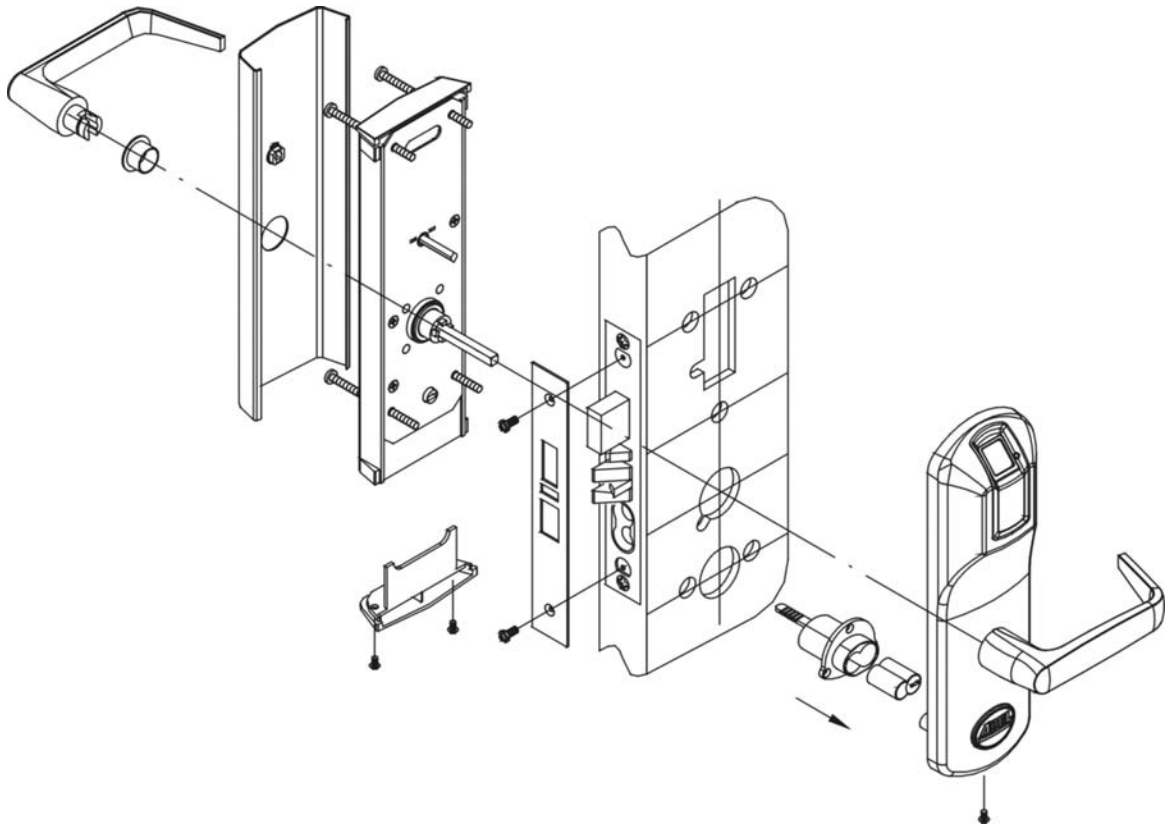

Diagram 6

- Step 11. Tighten the armature plate by two screws;
- Step 12. Test the lock as per operation instruction.

4. Strike Installation

- Step 1. Make the five latches of the lock extended until that they touch the side of the door frame and draw lines on the frame according to the position of latches to decide the upper and lower lines of the strike.
- Step 2. Measure the width of the latches to decide the left and right lines for the strike to be installed on the frame.
- Step 3. Cut a hole with chisel on the frame and install the strike.
- Step 4. Fix the strike with screws. (Refer to diagram 7)

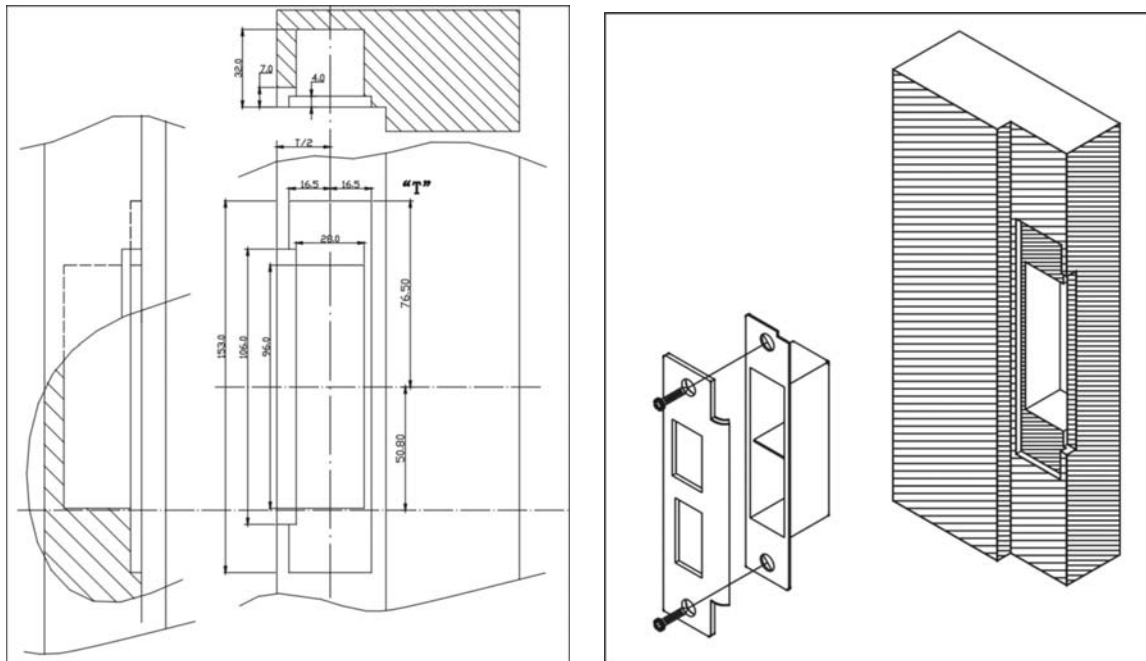
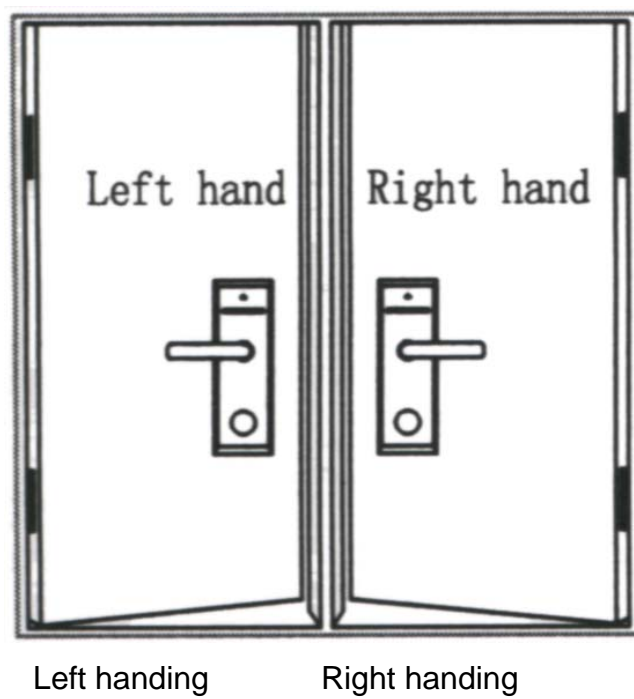

Diagram 7

B: Left Handing & Right Handing

Stand outside and face the door, if the hinge is on the left, then the lock is a Left Handing one; if the hinge is on the right, and then the lock is a Right Handing one. To be shown as follows.



----- End -----